

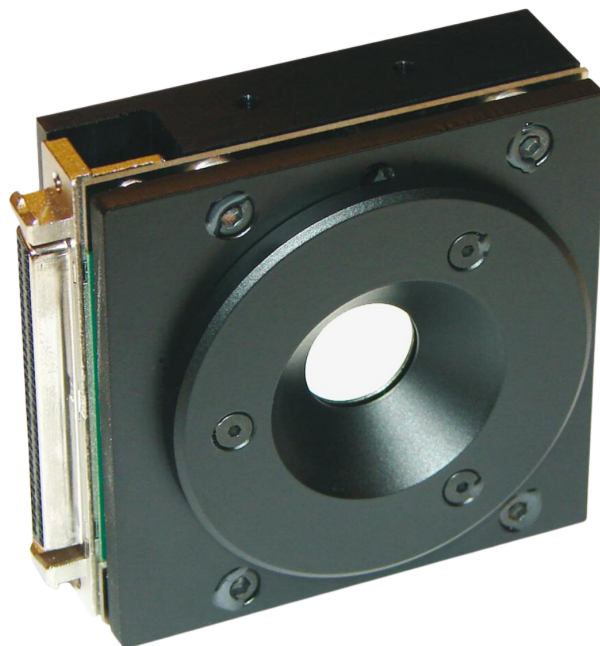

Mirao 52e

Deformable mirror
The looper

Designed for closed loop
Large amplitude
Exceptionnall surface quality



Mirao 52 family +

Boost your imaging performance :
Adaptive Optics made easy and efficient.

APPLICATIONS

- + **Ophthalmology** : Explore retinal cells at high resolution (contact our sister company Imagine Eyes for more informations)
- + **Microscopy** : Image deeper in your sample and/or navigate in 3D (for more details visit mu-Imagine website, our division dedicated to microscopy)
- + **Quantum applications**
- + **Beam shaping**
- + **Laser micromachining**
- + **Education**

FEATURES

- + **Fast closed-loop convergence and accurate correction** with high linearity and very low hysteresis
- + **Preserved photon budget** with achromatic, highly reflective and continuous membrane
- + **Long-term stability** with high stabilization option (Mirao 52es), allowing open-loop operation
- + **Correction up to 6th Zernike order** enabled by 52 electromagnetic actuators
- + **Protected version available** (Mirao 52ep) to prevent membrane mechanical damage

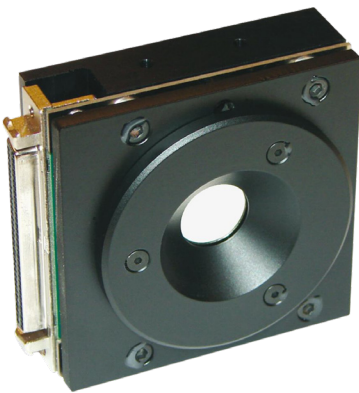

Mirao 52e



Mirao 52ep (protected)

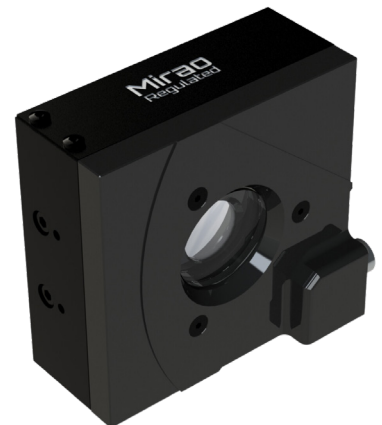

Mirao 52es (stabilized)

SPECIFICATIONS*

OPTICAL SPECS

Surface quality	<10 nm RMS
Coating	Protected silver
Linearity	> 95%
Hysteresis	< 2%

OPERATING SPECS

Number of actuators	52
Maximum generated wavefront (PV)	$\pm 50 \mu\text{m}$
Effective diameter	15 mm
Spatial frequency correction	Zernike orders up to 6
Rise time	2.4 ms
Temporal stability	< 10 nm RMS over 12h (stabilized option)

MISC

Dimension / Weight (Mirao 52e unit only)	$64 \times 64 \times 23 \text{ mm}^3 / 490 \text{ g}$
Dimensions / Weight (Mirao 52e controller)	$24 \times 23 \times 10 \text{ cm}^3 / 3 \text{ kg}$
Working environment	20-25°C, 20-80% RH
Interface / Power consumption	USB 2.0 / 50 W

OPERATING SYSTEM

Windows 10

*Subject to changes without further notice

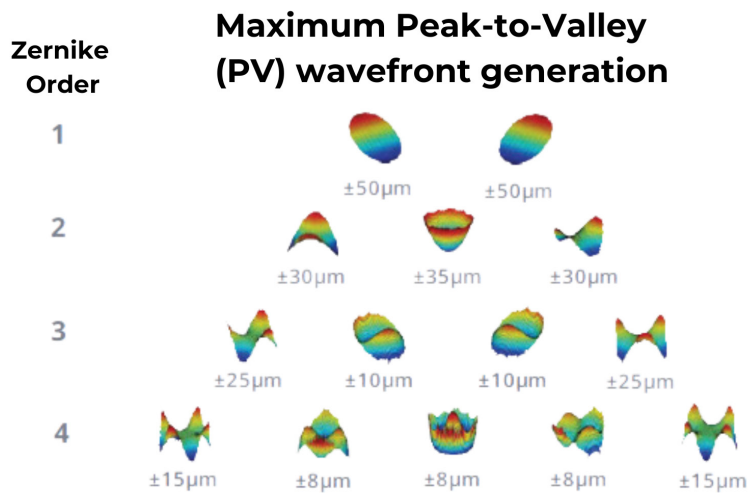

DIMENSIONS** (mm)

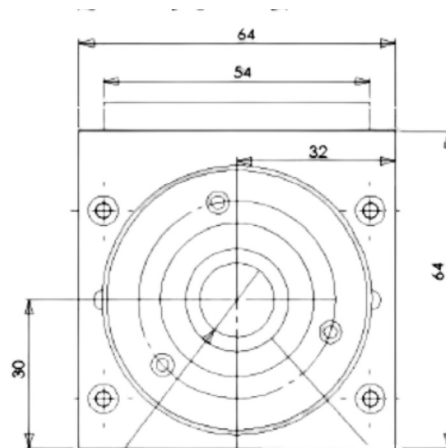
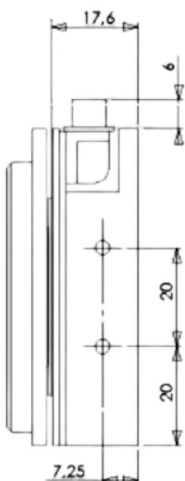

**Mirao 52e without controller

SOFTWARE

WAVETUNE

WAVETUNE is a unique software that seamlessly combines wavefront measurement and correction features with extensive instrument diagnostics.

This software contains all the necessary tools to calibrate the Deformable Mirror (DM). It can also operate the DM in closed-loop with HASO wavefront sensor, as well as in open-loop and perform beam shaping.

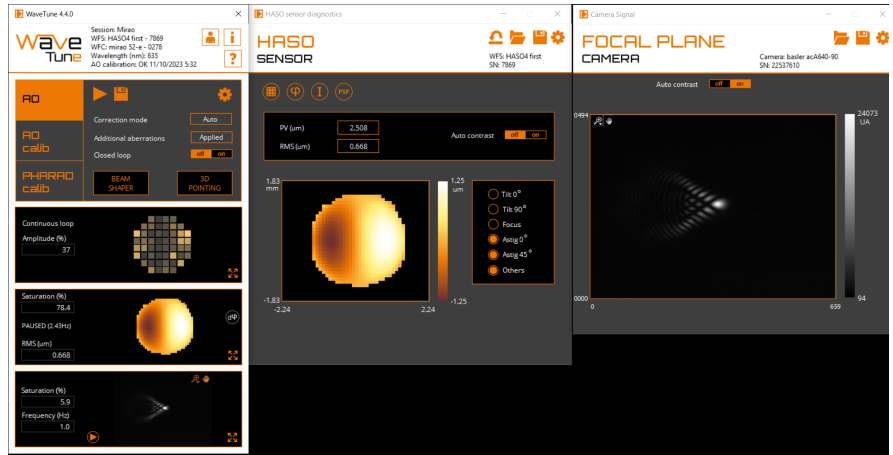

WAVEKIT BIO

WAVEKIT BIO is a Software Development Kit (SDK), available in C++ and Python, specifically designed for microscopy applications.

In particular, it contains all the necessary functions to implement sensorless AO, using image-based iterative algorithms (e.g. 3N).

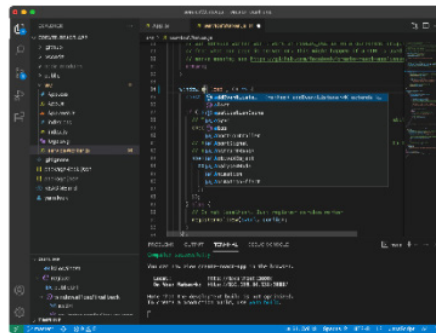

MOUNTING & ACCESSORIES

Several mounting options are available, including adaptors for the most common mechanical stages, to simplify integration of any Mirao 52 device into an optical setup.



CONTACT US

Imagine Optic Headquarters
18, rue Charles de Gaulle
91400 ORSAY · France
Phone +33 (0)1 64 86 15 60
sales@imagine-optic.com
www.imagine-optic.com

